

Features

- Location Indoor
- Function Occupancy and Light Sensor
- Type Ceiling
- Coverage 360°
- Coverage Area 450 Sq. ft.
- Ceiling Height 8 ft.
- Time Delay 30 sec – 30 min
- Lux Level 20 – 2000 Lux
- Sensitivity Max – Min
- Connection.Wired
- Drive Relay
- Dimming No

Description

The IOCHCW-WR1 is a 360° motion activated Occupancy and Light control sensor. The design is based on Passive infrared motion sensors technology and when implemented will significantly reduce the energy consumption for the end user. The sensor operates by detecting the movement of the infrared heat emitted from the body of an occupant in a given area of coverage or field of view. When it detects the presence of people, it will automatically turns on the light in the given area so the occupants will have adequate light to perform their work. The lights will be automatically turned OFF when the presence of occupants are no longer detected or when the combination of light (both external or natural light plus the installed lighting) exceeds the preset light level for the area provided the area is still occupied. By automatically turning ON and turning OFF lights the user will be able to save significant amount of energy (up to 60% depends on the usage pattern). This product is suitable for Indoor use only. This product is ideal for use in conference rooms, Cabins, Large halls, indoor alleyways or aisles and cafeteria.

Operation



The Occupancy sensor works by detecting the movement of infrared radiation emitted by humans. Whenever an occupant crosses the field of view of the Fresnel lens mounted in front of the IR sensor, the IR sensor detects a change in the energy received and assumes the area is occupied and turns on the lights automatically. As long as the sensor detects movement, it will maintain the lights in the ON position. When the movement is no longer detected, the sensor turns OFF the light after a preset delay. The light sensor will maintain the illumination in the room at a preset level as long as there is movement detected by the occupancy sensor. The sensor constantly measures the light level in the room, which includes the artificial light from the fixtures and the natural light coming from outside. The combination of both lights and the presence of humans in the area is used to maintain the light levels at a pre-set level by controlling (turning ON or OFF) the artificial fixtures.

Coverage Area

The IOLCLHx-WRRD has a circular sensing coverage area with a 24 feet diameter (450 Sq. feet) and a sensing angle of 360°, when installed at a height of 8 feet. Sensitivity can be adjusted to detect minor movements over a distance of 12 feet from the sensor. These sensors can be used individually or can be ganged together to increase the coverage area.

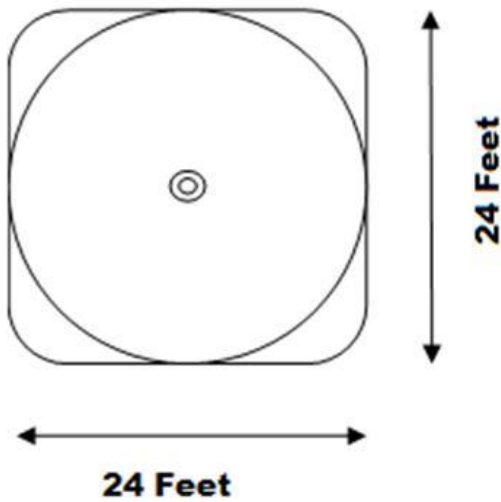

Standard installation

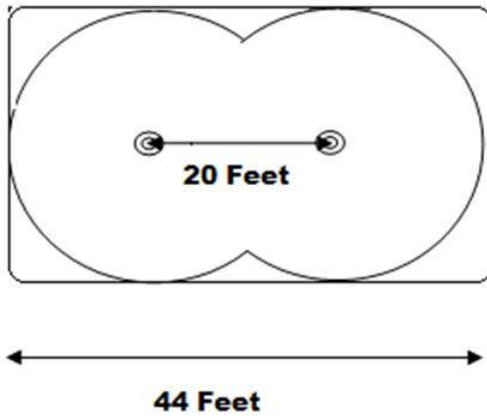

Parallel installation

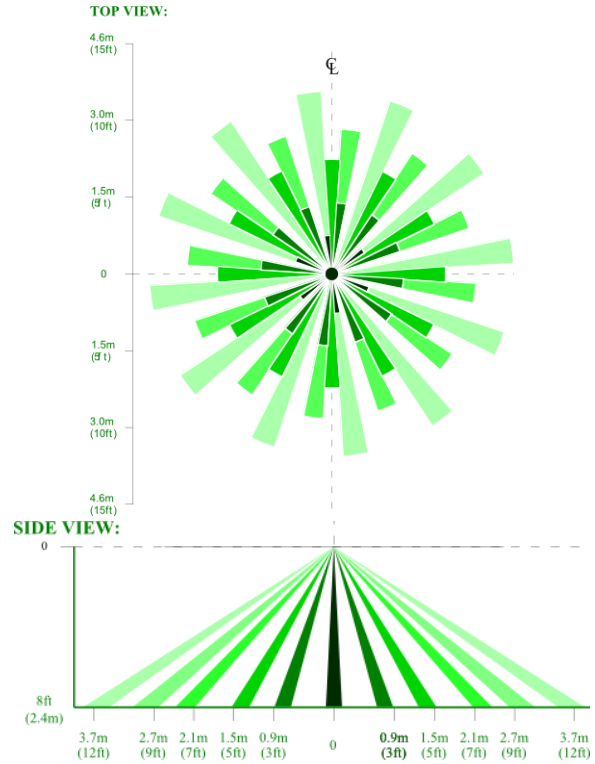

Electrical specifications

Supply voltage	85 – 265 VAC
Frequency	50/60 Hz
Resistive Load @110V	1000 W
Resistive Load @220 V	2000 W
Inductive Load @110V	500 W
Inductive Load @220 V	1000 W
Min load	No load
Wire Designation	Line-In – Red
	Line-Out - Blue
	Neutral – Black
	Aux-In -Brown

Environmental Specifications

Storage Temperature Range	0°C to 50°C
Relative Humidity	20% to 90% (non-condensing)

Mechanical Drawing

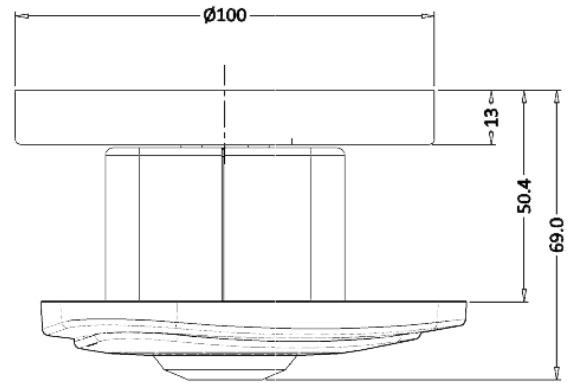
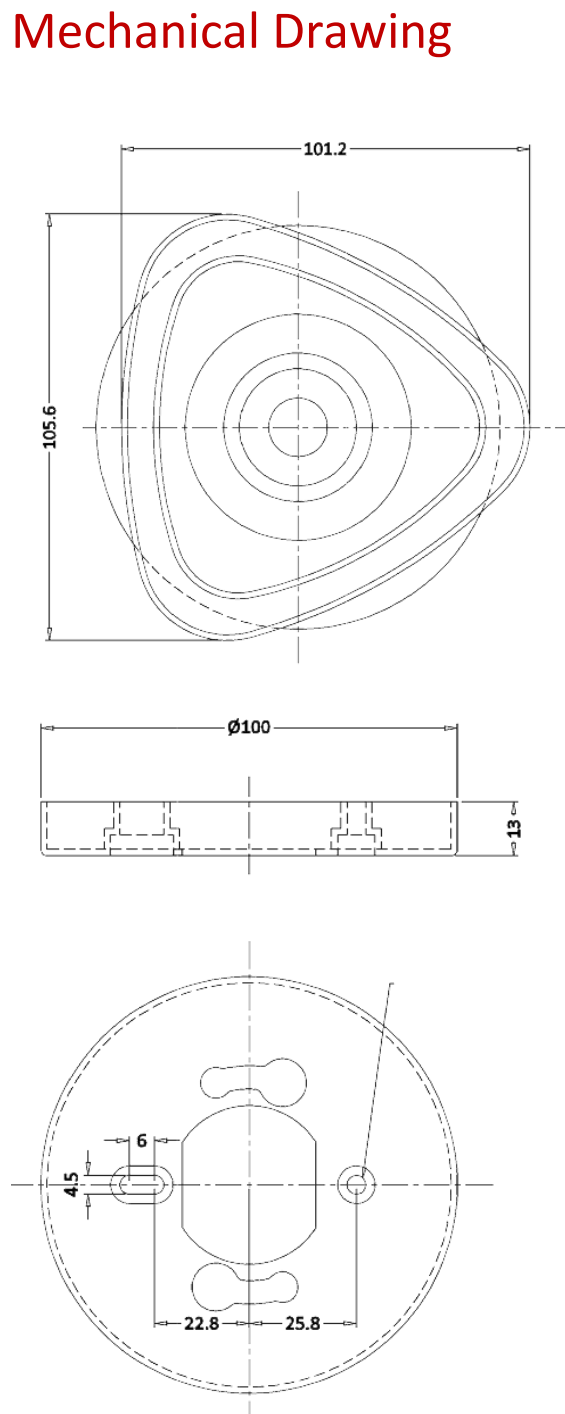

Supporting Documents

Review the following documents before installation. It will help you understand the sensor and fully exploit its capabilities

- 1) Ceiling Sensor Installation
- 2) Load specification- Relay Switching-Line
- 3) Manual Set up
- 4) Function definition and description
- 5) Troubleshooting
- 6) Daylight Harvesting